

TOASTMAX

CONVEYOR TOASTER



Model TM-10H

All the features of a high-end toaster... with a low-end price

The Hatco Toast-Max economy conveyor toaster offers the flexibility and performance to perfectly toast bread and buns fast – up to 300 slices per hour! Utilizing conveyor speed, not temperature, to determine toasting color, allows for instant adjustment of toasting time.

- 4-position toast selector switch: off / toast / buns / stand-by mode
- 89 mm (3 1/2") clearance to accommodate high profile bread products
- Easy-to-load rack with front or rear discharging
- Permanently lubricated 50/60 Hz motor
- V-shaped reflectors help capture and redirect heat
- Long lasting serpentine metal sheathed heating elements
- 102 mm (4") adjustable legs
- Pilot light that signals unit is in operation
- Discharge and crumb trays are removable for easy cleaning



Nothing less than the best.®



TOAST-MAX™ CONVEYOR TOASTERS

Models TM-5H, -10H

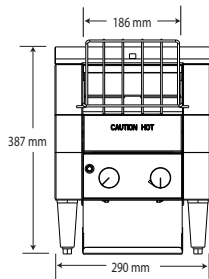

FRONT VIEW

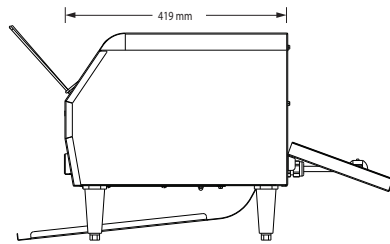

SIDE VIEW

Models TM-5H

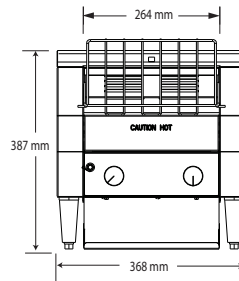

FRONT VIEW

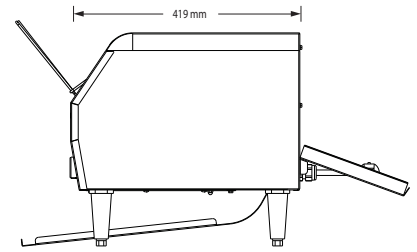

SIDE VIEW

Models TM-10H

SPECIFICATIONS

Model	kW	Type	Cap./Min.†	Shipping Weight
TM-5H	1.3	Bread & Buns	3 slices	16 kg(36 lbs.)
TM-10H	1.9	Bread & Buns	6 slices	19 kg(41 lbs.)

† Toasting capacity may vary by product. Toasting of coated products is not recommended.

SELECTOR CHART

(Based on serving 2 slices per customer.)

Number of Customers	Serving Time TM-5H	Serving Time TM-10H
30	24 minutes	12 minutes
60	48 minutes	24 minutes
90	72 minutes	36 minutes
120	96 minutes	48 minutes

DIMENSIONS

TM-5H: 290 W x 419 D x 387 H mm
 TM-10H: 368 W x 419 D x 387 H mm

Interior Cavity Openings:

TM-5H: 187 W x 88 mm H
 TM-10H: 264 W x 88 mm H

Maximum Product Size:

245 W x 64 mm H

CORD LOCATION

Left side of back of unit near center.

ELECTRIC RATING

Model	Volts	Watts	Amps	Hz
TM-5H	220-240	1340-1595	6.1-6.6	50-60
TM-10H	220-240	1940-2300	8.8-9.6	50-60

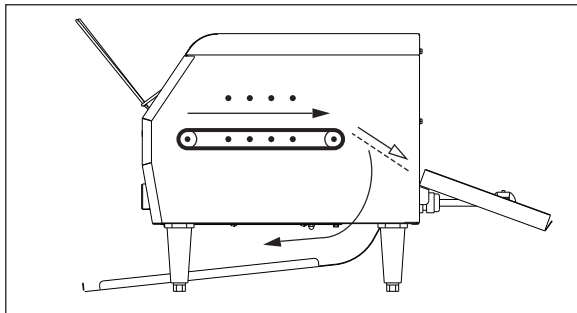

Product Flow



HATCO CORPORATION P.O. Box 340500 Milwaukee, WI 53234-0500 U.S.A. • (414) 671-6350 Int'l. Fax (414) 671-3976
 www.hatcocorp.com • E-mail: intlsales@hatcocorp.com